

ÖKO-SANTO SUPER



Automatic Refrigerator
Santo 1573TK-4

Operating Instructions

Dear customer,

Before placing your new refrigerator/freezer into operation please read these operating instructions carefully. They contain important information for safe use, for installation and for care of the appliance.

Please keep these operating instructions for future reference. Pass them on to possible new owners of the appliance.

These operating instructions are for use with several technically comparable models with varying accessories. Please observe the notes which apply to your model.



Notes which are important for your safety or for the proper functioning of the appliance are stressed with a warning triangle and/or with signal words (**Warning!**, **Caution!**, **Attention!**). Please observe the following carefully.



This symbol guides you step by step in the operation of the appliance.



Supplementary information regarding operation and practical applications of the appliance appear after this symbol.



Tips and notes concerning economical and environmentally sound use of the appliance are marked with the cloverleaf.

The operating instructions contain instructions for the correction of possible malfunctions by the user in the section "What to do if ...". If these instructions should not be sufficient, our customer service department is always available to you.

Printed on paper manufactured with environmentally sound processes.
he who thinks ecologically acts accordingly ...

Contents

Safety	4
Disposal	6
Appliance Packaging Information	6
Disposal of old Appliances	6
Remove transport safeguard	6
Installation	7
Installation Location	7
Your refrigerator needs air	8
Detaching the worktop	8
Mounting under a continuous worktop	9
Rehingeing the door	9
Changing over the freezer compartment door	10
Prior to Initial Start-Up	11
Electrical Connection	11
Starting up and temperature regulation	12
Interior Accessories	13
Storage shelves/wire trays	13
VARIO glass storage shelf	14
Correct storage	14
Freezing and storing frozen food	15
Preparation of Ice Cubes	16
Defrosting	16
The fridge defrosts automatically	16
Defrosting the freezer compartment	16
Switching off the appliance	17
Cleaning and Care	18
Energy Saving Tips	19
What to do if	20
Correcting Malfunctions	20
Changing the light bulb	22
Customer Service	23
Regulations, Standards, Guidelines	23

Safety

The safety aspects of our refrigerators/freezers comply with accepted technical standards and the German Appliance Safety Law. Nevertheless, we consider it our obligation to make you aware of the following safety information:

Intended use

- The refrigerator is intended for use in the home. It is suitable for the cooling, freezing and storing of frozen food, as well as for making ice. If the appliance is used for purposes other than those intended or used incorrectly, no liability can be accepted by the manufacturer for any damage that may be caused.
- Alterations or changes to the freezer are not permitted for reasons of safety.
- If you use the refrigerator in a commercial application or for purposes other than the cooling, freezing or frozen storage of foods, please observe all valid legal regulations for your application.

Prior to initial start-up

- Check the refrigerator for transport damage. Under no circumstance should a damaged appliance be plugged in! In the event of damage, please contact the vendor.

Refrigerant

The refrigerant isobutane (R600a) is contained within the refrigerant circuit of the appliance, a natural gas with a high level of environmental compatibility, which is nevertheless flammable.

- During transportation and installation of the appliance, be certain that none of the components of the refrigerant circuit become damaged.
- If the refrigerant circuit should become damaged:
 - avoid open flames and sources of ignition;
 - thoroughly ventilate the room in which the appliance is situated.

Safety of children

- Packaging (e.g. wraps, polystyrene) can be dangerous for children. There is a risk of suffocation! Keep packaging material away from children!
- Please make old appliances unusable prior to disposal. Pull out the mains plug, cut off the mains cable, break or remove spring or bolt catches, if fitted. By doing this you ensure that children cannot lock

themselves in the fridge when playing (there is risk of suffocation!) or get themselves into other dangerous situations.

- Often children cannot recognise the hazards present in household appliances. It is therefore important that you ensure adequate supervision and never let children play with the appliance!

Daily Operation

- Containers with flammable gases or liquids can leak at low temperatures. There is a risk of an explosion! Do not store any containers with flammable materials such as, for example, spray cans, fire extinguisher refill cartridges etc in the refrigerator/freezer.
- Bottles and cans must not be placed in the freezer compartment. They can burst when the contents freeze, high carbonate content drinks can even explode! Never store lemonade, juices, beer, wine, sparkling wine etc. in the freezer compartment. Exception: high alcohol content spirits can be stored in the freezer compartment.
- Do not put ice creams or ice cubes in the mouth immediately after removal from the freezer compartment. Very cold ice can freeze to the lips or tongue and cause injury.
- Do not touch frozen food with wet hands. Your hands could freeze to the food.
- Do not operate any electrical appliances in the refrigerator/freezer (e.g. electric ice cream makers, mixers etc.).
- Before cleaning the appliance, always switch off the appliance and unplug it, or pull the house fuse or switch off the circuit breaker.
- When unplugging always pull the plug from the mains socket, do not pull on the cable.

In case of malfunction

- If the a malfunction occurs on the appliance, please look first in the "What to do if ..." section of these instructions. If the information given there does not help, please do not perform any further repairs yourself.
- Refrigerators/freezers may only be repaired by qualified service engineers. Improper repairs can give rise to significant hazards. If your appliance needs repairing, please contact your specialist dealer or our Customer Service.

Disposal

Appliance Packaging Information

All materials are environmentally sound! They can be dumped or burned at an incinerating plant without danger!

About the materials: The plastics can be recycled and are identified as follows:

>PE< for polyethylene, e.g. the outer covering and the bags in the interior.

>PS< for polystyrene foam, e.g. the pads, which are all free of chlorofluorocarbon.

The carton parts are made from recycled paper and should be disposed of at a waste-paper recycling collection location.

Disposal of old Appliances

For environmental reasons, refrigeration appliances must be disposed of properly. This applies to your old appliance, and - at the end of its service life - for your new appliance as well.



Warning! Before disposing of old appliances make them inoperable. Remove plug from mains, sever the power cable, remove or destroy any snap or latch closures. This eliminates the danger that playing children lock themselves into the appliance (danger of suffocation!) or place themselves into other life-endangering situations.

Disposal:

- The appliance may not be disposed of with domestic waste or bulky refuse.
- The refrigerant circuit, especially the heat exchanger at the back of the appliance, may not be damaged.
- Information concerning collection schedules or locations can be obtained from the local disposal authorities or town hall.

Remove transport safeguard

The appliance and the interior fittings are protected for transport.



Pull off the adhesive tape on the left and right side of the door.



You can remove any remnants of adhesive using white spirit.



Remove all adhesive tape and packing pieces from the interior of the appliance.

Installation

Installation Location

The appliance should be set up in a well ventilated, dry room.

Energy use is affected by the ambient temperature.

The appliance should therefore

- not be exposed to direct sunlight;
- not be installed next to radiators, cookers or other sources of heat;
- only be installed at a location whose ambient temperature corresponds to the climate classification, for which the appliance is designed.

The climate classification can be found on the serial plate, which is located at the left on the inside of the appliance.

The following table shows which ambient temperature is correct for each climate classification: each climate classification:

Climate classification	for an ambient temperature of
SN	+10 to +32 °C
N	+16 to +32 °C
ST	+18 to +38 °C
T	+18 to +43 °C

If installation next to a source of heat is unavoidable, the following minimum clearances must be maintained at the sides of the appliance:

- for electric cookers 3 cm;
- for oil and coal fired ranges 30 cm.

If these clearances cannot be maintained a heat insulating pad is required between the cooker and the refrigeration appliance.

If the refrigeration appliance is installed next to another refrigerator or freezer a clearance of 5 cm at the sides is required, in order to prevent the formation of condensation on the outside of the appliance.

Your refrigerator needs air

The refrigerating unit of your refrigerator is designed for maintenance-free operation. What it should never lack is good ventilation. Air is supplied under the door through the ventilation slot between the refrigerator and a storage surface. Air is extracted through the upper ventilation grille. Never obstruct these openings by plinth screens or crockery.

If your refrigerator is installed under a continuous worktop, an air outlet opening of at least 200 cm² and a ventilation grille (A/B) matching the worktop design should be provided at the rear of the worktop. The cut surfaces of the worktop (C) should be varnished to avoid swelling due to penetration of moisture.

The appliance wall distance must be at least 30 mm and should be checked before the ventilation grille is inserted.

Special accessories:

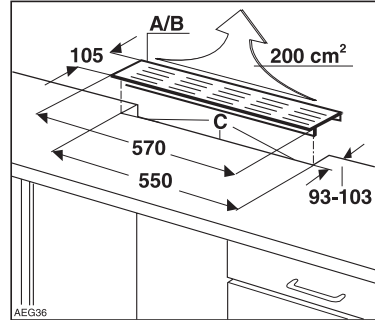

- A Ventilation grille, brown
- B Ventilation grille, white



Detaching the worktop

After the work-top has been removed the appliance can be installed underneath a continuous work-top.

The procedure is as follows:

-  Unscrew the Phillips screws (F) on the right and the left.
-  Lift the work-top slightly, push it about 20 mm towards the rear, and lift it off upwards (G). Unscrew the holding bracket (H) and keep it in a safe place.

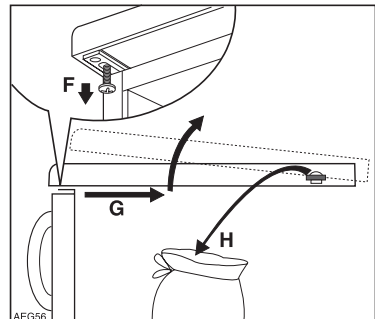

Mounting under a continuous worktop

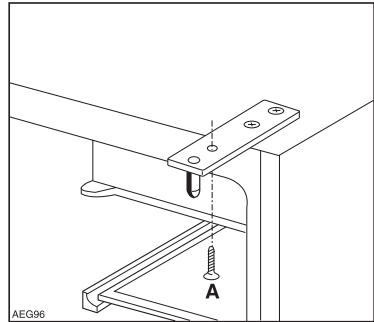

If installed under a continuous worktop, the appliance is fastened with a mounting screw (A) under the panel.







Rehinging the door

The side at which the door opens can be changed from the right side (factory adjustment) to the left side, if the installation site requires.

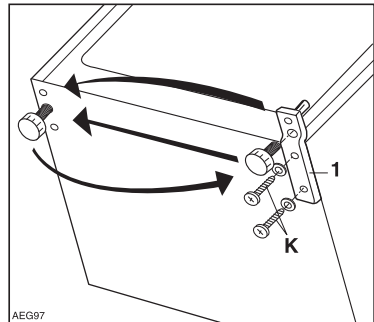
Warning! When changing the side at which the door opens, the appliance may not be connected to the mains. Remove plug from the mains beforehand.

-  Tilt the appliance slightly towards the rear and drop it securely.
-  Unscrew the door hinge screws (K) and take the door bearing (1) downwards out of its cavity.
-  Open the door a little way and take it out downwards.



-  Unscrew the upper pin (A) and screw it into place on the opposite side.
-  Fit the door into the upper pin (A) and close it.
-  Insert the pin of the door bearing (1) into the left hand cavity and screw the bearing firmly into place with the screws (K).

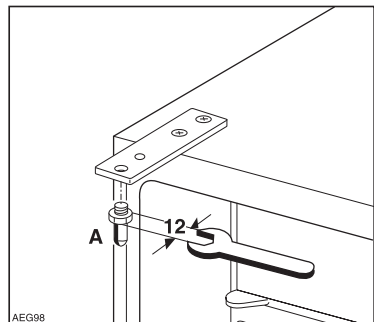

- ✎ Unscrew the handle. Refit it on the opposite side after having pierced the plugs with a punch. Cover the holes left open with the plugs contained in the documentation pack.

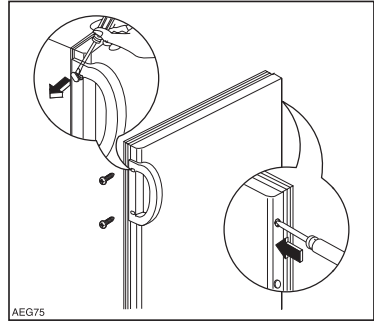

Changing over the freezer compartment door

- ✎ Open the freezer compartment door a little way.
- ✎ Using a small screwdriver, press the spring in the opening of the lower door bearing slightly upwards and take the door bearing out complete with the door.

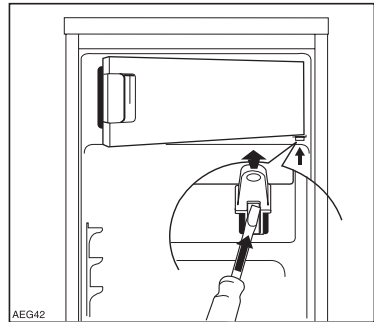

- ✎ Turn the covering cap (M) round.
- ✎ Turn the freezer compartment door through 180° and fit the lower door bearing into the lower bearing cavity of the freezer compartment door.
- ✎ Lift the freezer compartment door a little way upwards, fit it into the upper door bearing, and at the same time insert the lower door bearing into the square hole. Small upwards and downwards adjustments of the freezer compartment door will make fitting easier.

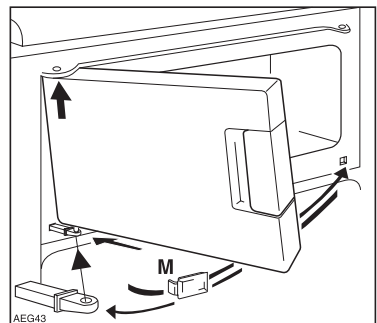

Prior to Initial Start-Up

-  Please clean the appliance interior and all accessories prior to initial start-up (see section: "Cleaning and Care").

Electrical Connection

Any electrical work required to install this appliance should be carried out by a qualified electrician or competent person.



WARNING – THIS APPLIANCE MUST BE EARTHED

The manufacturer declines any liability should these safety measures not be observed.

Before switching on, make sure the electricity supply voltage is the same as that indicated on the appliance rating plate. The rating plate is inside, on the left.

The appliance is supplied with a 13 amp plug fitted. In the event of having to change the fuse in the plug supplied, a 13 amp ASTA approved (BS 1362) fuse must be used.

Important

The wires in the mains lead are coloured in accordance with the following code:

Green and Yellow Earth
Blue Neutral
Brown Live

As the colours of the wires in the mains lead of this appliance may not correspond with the coloured markings indentifying the terminals in your plug, proceed as follows:

1. The wire coloured green and yellow must be connected to the terminal marked with the letter „E“ or by the earth symbol \oplus or coloured green and yellow.
2. The wire coloured blue must be connected to the terminal „N“ or coloured black.
3. The wire coloured brown must be connected to the terminal marked „L“ or coloured red.
4. Upon completion there must be not cut, or stray strands of wire present and the cord clamp must be secure over the outer sheat.



Warning! A cut-off plug inserted into a 13 amp socket is a serious safety (shock) hazard. Ensure that the cut-off plug is disposed of safely.

Plug socket

The plug socket necessary for connection of your appliance to the electricity supply should be positioned so that it is possible to pull out the appliance plug.

If your appliance is installed under a continuous worktop, the plug socket should be provided as shown.

A concealed protective contact plug socket requires 10 A/16 A fusing.

If the socket is not accessible once the appliance is built in, the electrical installation must include suitable means of isolating the appliance from the mains (e.g. fuse, cut-out, current trip or similar with a minimum contact separation of 3 mm).

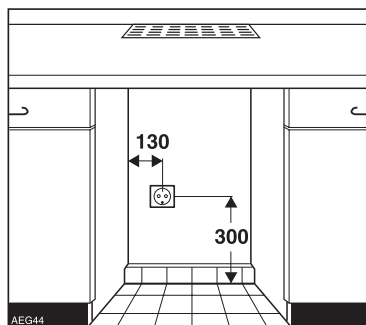

Starting up and temperature regulation

- ✎ Insert the plug of the connection lead into the plug socket with protective earth contact. When the refrigerator compartment door is opened, the internal lighting is switched on.

The temperature selector knob is located on the RH side of the refrigerator compartment.

Setting „0“ means: Off.

Turning clockwise in direction „1“: Refrigerating unit on, the latter then operating automatically.

Setting „1“ means:

Highest temperature, warmest setting.

Setting „6“ (end-stop) means:

Lowest temperature, coldest setting.

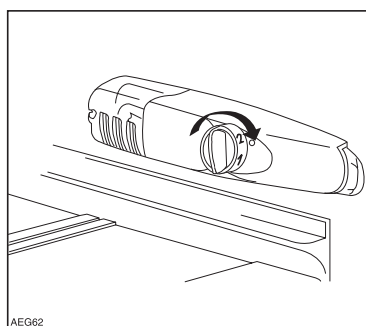

The temperatures in the refrigerator compartment and freezer compartment cannot be independently regulated.

At a low ambient temperature of around 16°C, setting „1“ should be selected. At ambient temperatures of around 25°C, select setting „2“.

If you require a lower temperature, select setting „3“ or „4“. On this setting, you can be sure the fresh food will be reliably frozen and that a storage temperature of -18°C will be maintained in the freezer compartment.

If you want the freeze fresh food rapidly, select setting „6“, ensuring that the temperature in the refrigerator compartment does not drop below 0°C. You should also promptly reset the temperature regulator to setting „3“ or „4“.

Important!

High ambient temperatures (e.g. on hot summer days) and a cold setting on the temperature regulator (position "5" to "6") can cause the compressor to run continuously.

Reason: when the ambient temperature is high, the compressor must run continuously to maintain the low temperature in the appliance. The fridge will not be able to defrost since automatic defrosting of the fridge is only possible when the compressor is not running (see also "Defrosting" section). The result is the build up of a thick layer of frost on the fridge rear wall.

If this happens, turn the temperature regulator back to a warmer setting (position "3" to "4"). At this setting the compressor will be switched on and off as usual and automatic defrosting recommenced.



Interior Accessories

Storage shelves/wire trays

Various glass or plastic storage shelves and wire trays are included with your appliance - different models have different combinations.

-  You should always slide one of the full size glass storage shelf into the lowest set of guides, above the fruit and the vegetable containers, and keep it in this position.

The height of the storage shelves can be adjusted:

-  To do this pull the storage shelf forward until it can be swivelled upwards or downwards and removed.
-  Please do the same in reverse to insert the shelf at a different height.

VARIO glass storage shelf

Your appliance is equipped with two half size glass storage shelves.

Storing tall items:

-  Slide the front half of the Vario storage shelf in another level to the rear. By this means you will gain space to place tall items on the storage shelf below.

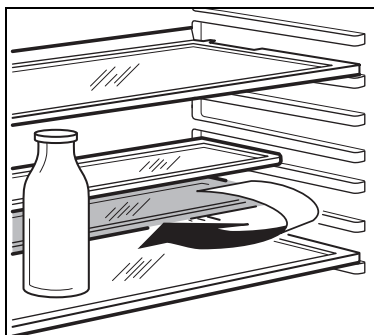

Correct storage

- ① Butter and cheese
- ② Eggs, tubes, preserves
- ③ Drinks
- ④ Cheese storage, fruit, and vegetables
- ⑤ Meat, salami, cold cuts, dairy produce
- ⑥ Ready meals, pastries, preserves
- ⑦ Frozen food storage/freezing food, icemaking

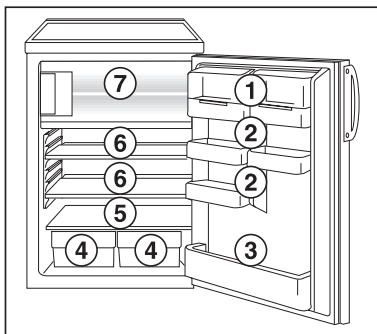

 This symbol means that deep-frozen food can be kept for some months in this compartment.

The length of storage time depends on the type of food – see manufacturer's instructions.

However, small quantities of fresh foods can be frozen (see: „Freezing and storage“).

Tip: Food in the fridge should always be covered or packaged, to prevent drying and tainting of other food.

The following are suited for packaging:

- Polyethylene airtight bags and wraps;
- Plastic containers with lids;
- Special plastic covers with elastic;
- aluminium foil.

Freezing and storing frozen food

The freezer compartment is for freezing and storing food.

Important!

- The temperature in the freezer compartment must be $-18\text{ }^{\circ}\text{C}$ or colder before freezing food or storing food already frozen.
- Do not freeze too large a quantity at any one time (max. 2 kg per 24 h). The quality of the food is best preserved when it is frozen right through to the core as quickly as possible.
- Allow warm food to cool down before freezing. The warmth will cause increased ice formation and increase the power consumption.
- Please note the maximum storage times specified by the manufacturer.
- Thawed foods which have not been processed further (cooked into meals) may not under any circumstances be frozen a second time.

 All foods must be packed air tight prior to freezing, so that they do not dry out or lose their flavour, and so that no flavour contamination of other frozen goods occurs.



Caution! Do not touch frozen food with wet hands. Your hands could freeze to the food.

 Lay the packaged food on the floor of the freezer compartment. Unfrozen food must not touch items already frozen, otherwise the frozen food could begin to defrost.

Tips:

- The following are suited for the packaging of frozen goods:
 - freezer bags and polyethylene wraps;
 - special cans for frozen goods;
 - extra-thick aluminium foil.
- The following are suitable for sealing bags and wrap:
plastic clips, rubber bands or tape.
- Smooth the air out of the bag before sealing; air makes it easier for the frozen food to dry out.
- Make flat packages, because these freeze more quickly.
- Do not fill cans for frozen goods to the brim with liquid or paste-like goods, because liquids expand during freezing.

Preparation of Ice Cubes

-  Fill the ice cube tray 3/4 full with cold water, place it in the freezer compartment and leave to freeze.
-  To loosen the frozen cubes, either bend the ice cube tray or hold it under running water for a few seconds.

Important! Never try to free an ice tray that is frozen to the freezer compartment using pointed or sharp edged objects, since you may damage the refrigerating circuit. Use the plastic scraper.

Defrosting

The fridge defrosts automatically

The rear wall of the fridge covers with frost when the compressor is running, and defrosts when the compressor is off.
The water from the thawing frost evaporates by itself.

Defrosting the freezer compartment

During use and when the freezer compartment door is opened, moisture is deposited in the freezer compartment as frost. Remove this frost from time to time with the soft plastic scraper. Under no circumstances use hard or pointed objects to remove frost.

The freezer compartment should always be defrosted when the layer of frost has reached a thickness of approx. 4 millimetres; however at least once a year. A good time for defrosting is when the appliance is empty or contains only little food.



Warning!

- Do not use electrical heating appliances or any other mechanical or artificial devices to speed up the defrosting process, with the exception of those recommended in these operating instructions.
- Do not use defrosting sprays, they can be hazardous to your health and/or contain substances that damage plastics.

Caution! Do not touch frozen food with wet hands. Your hands could freeze to the food.

-  Remove frozen food, wrap it in several layers of newspaper and store it, covered, in a cool place.

- ☞ Switch off the appliance and unplug it, or pull the fuse or switch off the circuit breaker.
- ☞ Remove the stopper from the melt-water outlet and place a bowl underneath it to catch the melt-water.

Tip: You can speed up the defrosting process by placing a pan with hot water in the freezer compartment and closing the doors. Remove pieces of ice that have fallen before they completely defrost.

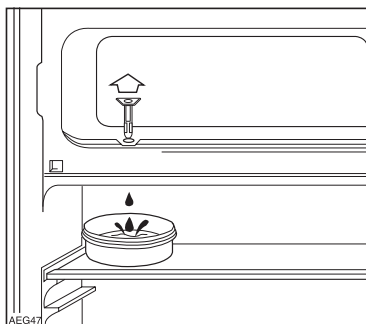

- ☞ After defrosting, thoroughly clean the freezer compartment (see "Cleaning and Care" section).

Switching off the appliance

- ☞ To switch off the appliance, turn the temperature regulator to position "0".

If the appliance is not going to be used for an extended period:

- ☞ Remove all refrigerated and deep-frozen packages as well as ice-trays.
- ☞ Switch off the appliance by turning the temperature regulator to position "0".
- ☞ Remove the mains plug or switch off or turn out the circuit breaker or fuse.
- ☞ Defrost freezer compartment and clean thoroughly (see section: "Cleaning and Care").
- ☞ Leave the door open to avoid the build up of odours.

Cleaning and Care

For hygienic reasons the appliance interior, including interior accessories, should be cleaned regularly.



Warning!

- The appliance may not be connected to the mains during cleaning. Danger of electrical shock! Before cleaning switch the appliance off and remove the plug from the mains, or switch off or turn out the circuit breaker or fuse.
- Never clean the appliance with a steam cleaner. Moisture could accumulate in electrical components, danger of electrical shock! Hot vapours can lead to the damage of plastic parts.
- The appliance must be dry before it is placed back into service.

Attention!

- Ethereal oils and organic solvents can attack plastic parts, e.g.
 - lemon juice or the juice from orange peels;
 - butyric acid;
 - cleansers which contain acetic acid.Do not allow such substances to come into contact with appliance parts.
- Do not use any abrasive cleansers.



Remove frozen food and the food from the refrigerator. Wrap frozen food in several layers of newspaper. Store it in a cool place, well covered.



Defrost the freezer compartment prior to cleaning (see "Defrosting" section).



Switch the appliance off and remove the plug from the mains, or switch off or turn out the circuit breaker or fuse.



Clean the appliance and the interior accessories with a cloth and lukewarm water. Commercially available dish washing detergents may also be used.



After cleaning wipe with fresh water and rub dry.



Accumulation of dust at the condenser increases energy consumption. For this reason carefully clean the condenser at the back of the appliance once a year with a soft brush or a vacuum cleaner.

 Check the water drain hole on the rear wall of the fridge. Clear a blocked drain hole with the aid of the green peg in the pack of accessories included with the appliance.

 After everything is dry place appliance back into service.

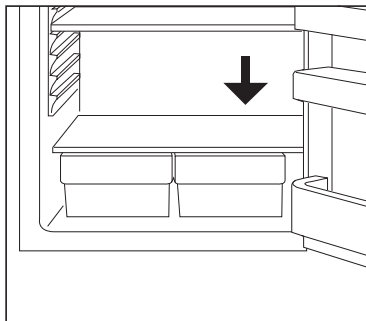

Energy Saving Tips

- Do not install the appliance near cookers, radiators or other sources of warmth. High ambient temperatures cause longer, more frequent operation of the compressor.
- Ensure sufficient air circulation and exhaust at the appliance base and at the back wall of the appliance. Never cover air vent openings.
- Do not place warm foods into the appliance. Allow warm foods to cool first.
- Only leave door open as long as necessary.
- Do not set temperature any colder than necessary.
- Put frozen food in the fridge to defrost. The cold in the frozen food will then be used to cool the fridge.
- Keep the heat emitting condenser, the metall grille on the rear wall of your appliance, always clean.

What to do if ...

Correcting Malfunctions

Spare parts:

Minor repairs you can carry out yourself, spare parts can be ordered from the service centre. You can fit these yourself without any special skill or training, e.g.:

- butter/cheese compartment,
- egg holders,
- door racks,
- fruit and vegetable drawers,
- storage racks

A malfunction may be caused by only a minor fault that you can rectify yourself using the following instructions. Do not perform any other work on the appliance if the following information does not provide assistance in your specific case.



Warning! Repairs to refrigerators/freezers may only be performed by qualified service engineers. Improper repairs can give rise to significant hazards for the user. If your appliance needs repairing, please contact your specialist dealer or our Customer Service.

Malfunction	Possible Cause	Remedy
Appliance does not work.	Appliance is not switched on.	Switch on the appliance.
	Mains plug is not plugged in or is loose.	Insert mains plug.
	Fuse has blown or is defective.	Check fuse, replace if necessary.
	Socket is defective.	Mains malfunctions are to be corrected by an electrician.
Appliance cools too much.	Temperature is set too cold.	Turn the temperature regulator to a warmer setting temporarily.

Malfunction	Possible Cause	Remedy
The food is too warm.	Temperature is not properly adjusted.	Please look in the "Initial Start Up" section.
	Door was open for an extended period.	Open the door only as long as necessary.
	A large quantity of warm food was placed in the appliance within the last 24 hours.	Turn the temperature regulator to a colder setting temporarily.
	The appliance is near a heat source.	Please look in the "Installation location" section.
Interior lighting does not work.	Light bulb is defective.	Please look in the "Changing the Light Bulb" section.
Heavy build up of frost, possibly also on the door seal.	Door seal is not air tight (possibly after changing over the hinges).	Carefully warm the leaking sections of the door seal with a hair dryer (not hotter than approx. 50 °C). At the same time shape the warmed door seal by hand such that it sits correctly.
Unusual noises.	Appliance is not level.	Readjust the feet.
	The appliance is touching the wall or other objects.	Move the appliance slightly.
	A component, e.g. a pipe, on the rear of the appliance is touching another part of the appliance or the wall.	If necessary, carefully bend the component out of the way.
The compressor does not start immediately after changing the temperature setting.	This is normal, no error has occurred.	The compressor starts after a period of time.
Water on the floor or on storage shelves.	Water drain hole is blocked.	See the "Cleaning and Care" section.

Changing the light bulb



Warning! There is a risk of electric shocks! Before changing the light bulb, switch off the appliance and unplug it, or pull the fuse or the circuit breaker.

Light bulb data: 220-240 V, max. 15 W



To switch off the appliance, turn the temperature regulator to position "0".



Unplug the mains plug.



To change the light bulb, undo the screw.



Press the light bulb cover as shown and slide it backwards.



Change the defective light bulb.



Refit the light bulb cover and the screw.



Put the refrigerator back into operation.

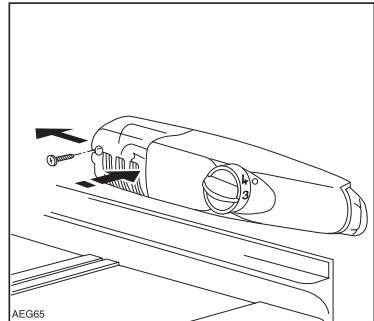

Customer Service

If you cannot find the remedy for a malfunction in these operating instructions, please contact your dealer or our customer service department. Addresses and telephone numbers are listed in the accompanying booklet "Guarantee Conditions/Customer Service Locations".

Selective ordering of replacement parts can save unnecessary travel and costs. For this reason always provide the following appliance information:

This information can be found on the serial plate in the interior at the

- Model Name 
- Model Number (PNC) 
- Serial Number (S-No.) 

left of the appliance. We recommend that you enter this information here, so that it is handy if needed.

Note: The customer bears the costs of unjustified customer service calls even during the guarantee period.

Regulations, Standards, Guidelines

This appliance was designed for household use and was manufactured in accordance with the appropriate standards. The necessary measures in accordance with appliance safety legislation regulations (GSG), accident prevention regulations for refrigeration appliances (VBG 20) and the regulations of the German Society of Electrical Engineers (VDE) were observed in the manufacture of this appliance.

The refrigerant circuit has been checked for leaks.

- CE** This appliance is in accordance with the following EU guidelines:
- 73/23/EEG dated 19 February 1973 - low voltage guidelines.
 - 89/336/EEG dated 3 May 1989
(including guideline change notice 92/31/EEG) - EMV guideline

AEG Hausgeräte GmbH
Postfach 1036
D-90327 Nürnberg

<http://www.aeg.hausgeraete.de>

© Copyright by AEG

H 271 286 200-01-0298

2222 649-51